

Revision			
Rev.	Description	Date	Approved
A-2		2014/11/05	RD

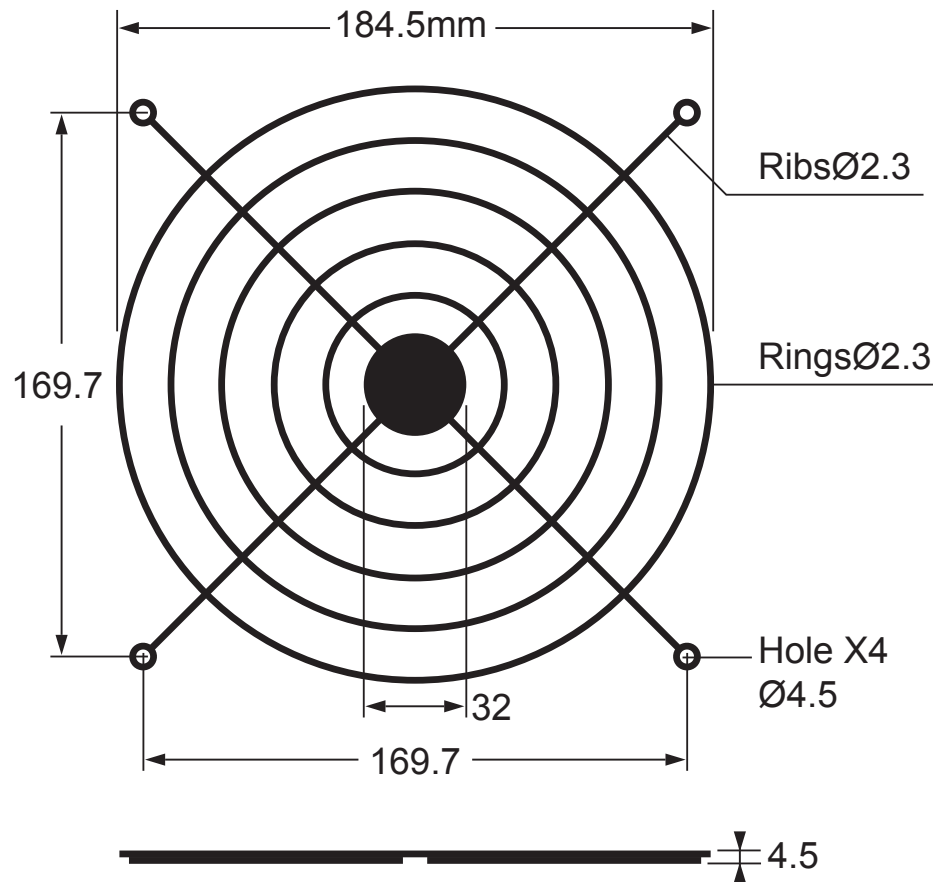

Specifications:

1. General tolerance unless noted is $\pm 0.5\text{mm}$
2. Hole to Hole: $169.7\text{mm} \pm 0.5\text{mm}$
3. Holes dia.: $4.5\text{mm} \pm 0.2\text{mm}$
4. Outer ring dia.: $184.5\text{mm} \pm 0.5\text{mm}$
5. Ring dia.: $2.3\text{mm} \pm 0.1\text{mm}$
6. Rib dia.: $2.3\text{mm} \pm 0.1\text{mm}$
7. Height.: $4.5\text{mm} \pm 0.2\text{mm}$
8. Stagger welds: 5 rings

Material:

- Rings & Ribs Steel wire SAE 1006 AL-KILLED (MQ)
- Surface Treating
Black electro deposit
- Weld Joins Contact Strength
Spot welding Points to withstand min. 88lbs(40Kgs.)
- Weight: 85.0Gm



Sinwan Electric Industries Co., Ltd.

Part Number:

G225-5DFB

Description:

Metal Fan Guard For 205mm (8.1") Fan